

GESTRA Steam Systems

Product Range Group B

Rapid-Action Intermittent Blowdown Valves

(M)PA 46, PN 40, DN 20-50

(M)PA 47, PN 63, DN 25, 40, 50

(M)PA 110, PN 250, DN 25

(M)PA 46

(M)PA 47

(M)PA 110



Specification

Manual or automatic, programme-controlled intermittent blowdown of land and marine boilers, in particular boilers operating without constant supervision in accordance with TRD 604 (German regulations concerning the operation of steam boilers).

Description

The valves type MPA are provided with a diaphragm actuator suitable for compressed air or pressurized water and a rapid-closing mechanism. The opening pulse is supplied by the automatic intermittent blowdown control unit type TA (cf. data sheet TA) or by the continuous blowdown controller LRR 1-40 SPECTORcontrol with CAN bus (cf. data sheet LRR 1-40). The valves type PA are manually operated and feature a rapid-action mechanism.

Design

(M)PA 46 / (M)PA 47

Straight-through valves with rapid-closing mechanism and diaphragm actuator designed with flanged ends or butt-weld ends. MPA with diaphragm actuator, PA with hand lever (fastening clip). Self-tightening stuffing box with separate, externally adjustable preloading sleeve. The valve is provided with a radial stage nozzle.

(M)PA 110

Straight-through valve with rapid-closing mechanism and diaphragm actuator designed with flanged ends or butt-weld ends. MPA with diaphragm actuator, PA with hand lever.

Connections		
Type	Standard	On request
(M)PA 46	Flanges PN 40	Flanges to Class 150, 300 Butt-weld ends for DIN or ASME pipes Socket-weld ends for DIN or ASME pipes
(M)PA 47	Flanges PN 63	Flanges to Class 400 Butt-weld ends for DIN or ASME pipes Socket-weld ends for DIN or ASME pipes
(M)PA 110	Butt-weld ends for DIN pipe 33.7 x 3.6	Other butt-weld ends Socket-weld ends to DIN or ASME Flanges acc. to DIN or ASME

Pressure Ratings			
(M)PA 46		PN 40	Class 150, 300
(M)PA 47		PN 63	Class 400
(M)PA 110		PN 250	Class 900/1500

Materials (M)PA 46, (M)PA 47			
Designation	DIN EN	DIN reference	ASTM equivalent
Body	P250GH (1.0460)	C 22.8 (1.0460)	A 105
Stuffing box union	P250GH (1.0460)	C 22.8 (1.0460)	A 105
Sealing plug	42CrMo4 (1.7225)		A193 B7
Gasket	X5CrNi18-10 (1.4301)	X 5 CrNi 18 10 (1.4301)	
Seat, hardened	X46Cr13 (1.4034)	X 46Cr 13 (1.4034)	
Valve cone, hardened	X39CrMo17-1 (1.4122)	X 35 CrMo 17 (1.4122)	
Disk springs	51CrV4 (1.8159)	50 CrV 4 (1.8159)	
Compression springs	EN 10270-1-SH	DIN 17223-C	
Diaphragm actuator		StW 23 (1.0334)	
Packing		PTFE yarn	
Control fluid		EPDM	

Materials (M)PA 110			
Designation	DIN EN	DIN reference	ASTM equivalent
Body	13CrMo4-5	13 CrMo 4 4 (1.7335)	
Valve yoke	P250GH	C 22.8 (1.0460)	A 105
Seat, hardened	X6CrNiMoTi17-12-2	X 6 CrNiMoTi 17 12 2 (1.4571)	
Valve cone, hardened	X6CrNiMoTi17-12-2	X 6 CrNiMoTi 17 12 2 (1.4571)	
Bolt *)	21CrMoV5-7	21 CrMoV 5 7 (1.7709)	
Nut*)		24 CrMo 5 (1.7258)	A194 4
Packing		Graphite	
Valve head	EN-GJMW-350-4	GTW-35-04 (0.8035)	
Compression spring	EN 10270-1-SH	DIN 17223-C	

*) Pressure-bearing part

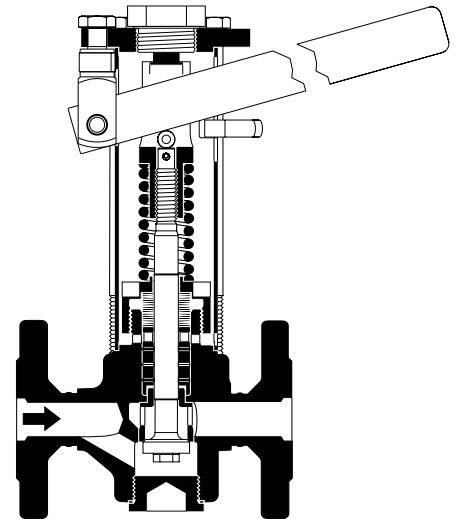

PA 46 / PA 47

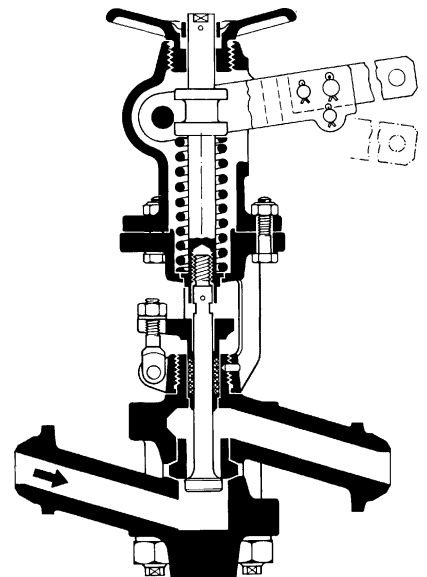

PA 110

Blowdown Intervals and Blowdown Duration

When opening a GESTRA intermittent blowdown valve, its quick-opening action creates a suction effect causing the sludge to be blowdown. This desludging operation automatically provides simultaneous desalting.

A blowdown period – opening period of the valve – lasts approx. 2 seconds. To be able to determine the periods when blowdown is to be repeated it is necessary to know the quantity of boiler water to be discharged.

- The formula on page 4 calculates the boiler-water quantity in kg/h to be discharged to keep the boiler-water conductivity below the admissible value, e. g.: **10 kg/h**
- Chart 1 gives the discharge capacity blowdown in kg/s for the existing valve or the valve suitable for the size of the boiler standpipe e. g. **2.5 kg/s**
- The blowdown duration can now be calculated, in this case **4 seconds** per hour.
Since the blowdown valve stays only open for **2 seconds** during each blowdown operation, this implies 2 operations per hour. The blowdown interval is therefore $60 : 2 = \mathbf{30 \text{ minutes}}$.

The automatic intermittent blowdown control unit TA..., LRR 1-40 (see separate data sheets) provides the following programme:

Blowdown duration (opening period) normally 2 seconds.
Blowdown interval adjustable, e. g. 30 minutes.

It is of course possible to adjust larger intervals, i. e. to blowdown less frequently and to use a GESTRA Reactomat BA or BAE for continuous desalting.

Heat recovery of continuous desalting processes provides significant energy and cost savings.

Pressure / Temperature Ratings

Acc. to EN 1092-1 for: 1.0460 acc. to PED and AD 2000 or A 105 acc. to PED

	Ratings according to		max. pressure [bar] at [t] =					Max. actuating force PA... [N]		Control fluid MPA...	Max. control pressure MPA...
			100 °C	200 °C	300 °C	400 °C	ts/p max.	20 – 32	40, 50		
(M)PA 46	PN 40 1.0460	EN 1092-1	37.3	30.2	25.8		234/29	290	460	Water or compressed air	8 bar
	PN 40 A105	EN 1092-1	40	37.9	33.5		246/36	320	530		
	Class 150 A105	ASME B16.34	17.7	14.0	10.2		198/14	230	310		
	Class 300 A105	ASME B16.34	46.4	43.9	38.9		254/41	340	580		
(M)PA 47	PN 63 1.0460	EN 1092-1	58.8	47.6	40.6		257/44	360	620		
	PN 63 A105	EN 1092-1	63	59.6	52.7		271/55	410	730		
	Class 400 A105	ASME B16.34	61.8	58.4	51.7		270/54	400	720		
(M)PA 110	PN 250 1.7335	EN 1092-1	250	250	227.7	200	369/206	800		Compressed air	6 bar
	PN 250 A182-F12	EN 1092-1	250	250	243	226.5	374/221	850			
	Class 600 A182-F12	ASME B16.34	103	95.8	85.7	73.3	300/85	400			
	Class 900 A182-F12	ASME B16.34	154.4	143.9	128.6	109.8	326/124	540			
	Class 1500 A182-F12	ASME B16.34	257.4	239.7	214.4	183.1	363/196	790			

Retrofit sets

Diaphragm actuator unit for

PA 46 / 47: **335093**

Comprises: diaphragm actuator with spacer disk

Manual emergency operating device for

MPA 46 / 47: **335060**

Comprises: emergency operating lever, clevis, toggle bolt, hexagon-head screw

Proximity switch

MPA 46 / 47: **335140**

Comprises: two proximity switches, mounting bracket, two disconnecting switch amplifiers

Enquiry Specification

MPA

Rapid-action intermittent blowdown valves with diaphragm actuator and rapid-closing mechanism.

Indications on nominal pressure (PN), nominal size (DN), connections, service pressure, back pressure, temperature, fluid, application (e. g. type of boiler).

Specifications on intermittent blowdown control: TA..., LRR 1-40, solenoid valves 230 V, 50/60 Hz.

PA

Rapid-action intermittent blowdown valve with hand-lever actuation, with rapid-closing mechanism and locking device.

Indications on nominal pressure (PN), nominal size (DN), connections, service pressure, back pressure, temperature, fluid, application (e. g. type of boiler).

Please note

When sizing pipes please take torsional and bending moments, which occur when the hand lever of PA... is set crosswise or lengthwise to the pipe, into account. The max. actuating forces are indicated in the table "Pressure / Temperature Rating".

To avoid waterhammer we recommend that the pipe downstream of the intermittent blowdown valve has a downward inclination or to drain the pipe before carrying out the intermittent boiler blowdown.

The pipe length between the steam boiler and the intermittent blowdown valve must not exceed two meters!

PA 46 / PA 47

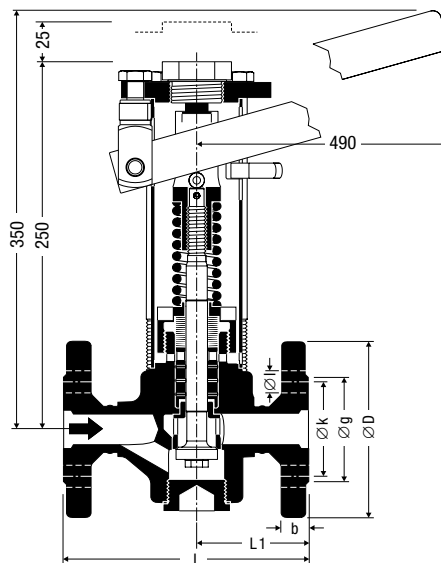

PA 110

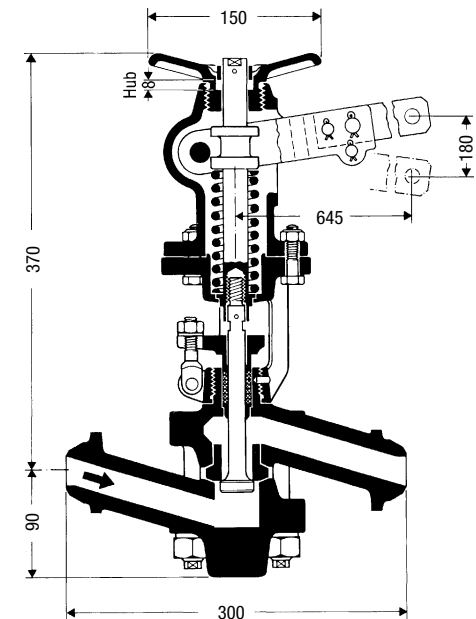

Dimensions and weights

(M)PA 46, (M)PA 47 DN 20 – 50						
DN	[mm] [in]	20 ¾	25 1	32 1¼	40 1½	50 2
Flanged Class 150	L	150	160	180	230	230
	L1	68	73	83	98.5	98.5
Flanged Class 300	L	150	160	180	230	230
	L1	68	73	83	98.5	98.5
Flanged Class 400	L		216		216	250
	L1		101		91.5	108.5
Butt-weld ends via transition pieces	L	200	200	200	250	250
	L1	93	93	93	108.5	108.5
Socket-weld ends	L	200	200	200	250	250
	L1	93	93	93	108.5	108.5
Flanged DIN PN 40	L	150	160	180	200	230
	L1	68	73	83	83.5	98.5
	D	105	115	140	150	165
	k	75	85	100	110	125
	g	58	68	78	88	102
	b	18	18	18	18	20
	l	14	14	18	18	18
Number of bolts	n	4	4	4	4	4
Flanged DIN PN 63	L		190		220	250
	L1		88		73.5	108.5
	D		140		170	180
	k		100		125	135
	g		68		88	102
	b		24		26	26
	l		18		22	22
Number of bolts	n		4		4	4
Weight MPA [kg]	m	13.9	14.5	15.8	18.9	20.7
Weight PA [kg]	m	8.8	9.4	10.7	13.8	15.6

(M)PA 110, PN 250, DN 25						
DN	[mm] [in]	20 ¾	25 1	32 1¼	40 1½	50 2
Flanged DIN PN 100/160	L		390			
Flanged DIN PN 250	L		410			
Flanged Class 600	L		410			
Flanged Class 900/1500	L		440			
Butt-weld end	L		300			
Butt-weld ends via transition pieces	L		400			
Weight MPA 110 [kg]*			37 (30)			
Weight PA 110 [kg]*			29 (22)			

*) Butt-weld ends and butt-weld ends via transition pieces

Control pressure (M)PA 46 / (M)PA 47

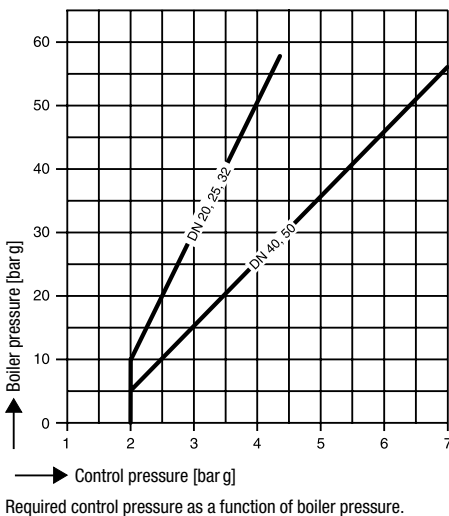

Control pressure (M)PA 110

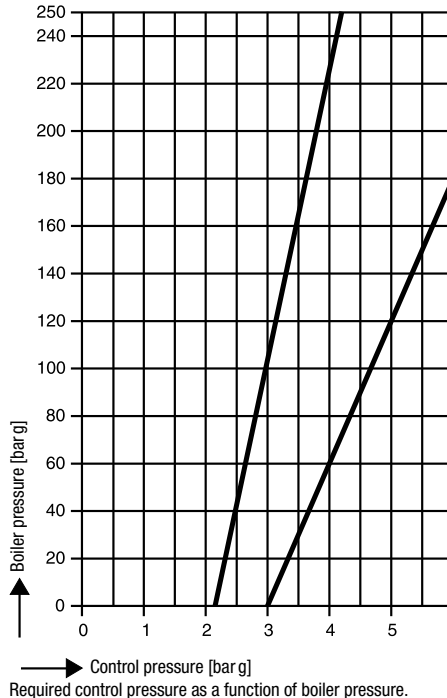

MPA 46, MPA 47

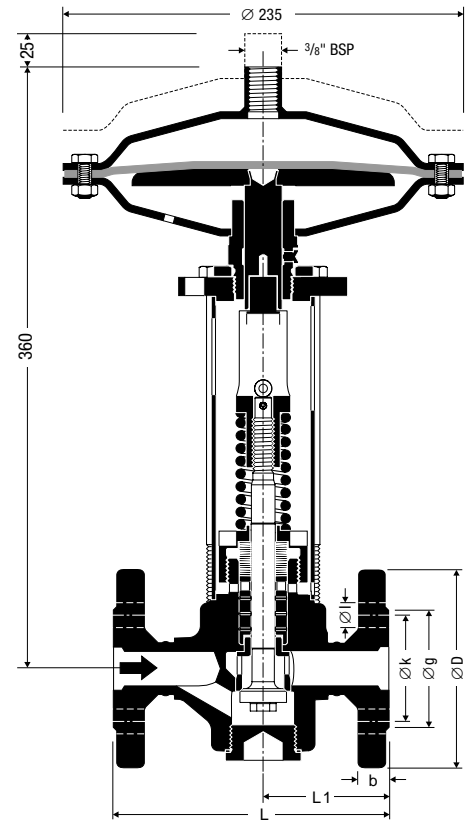

MPA 110

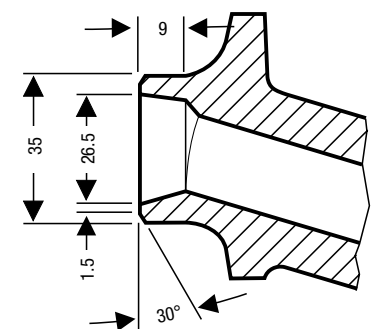
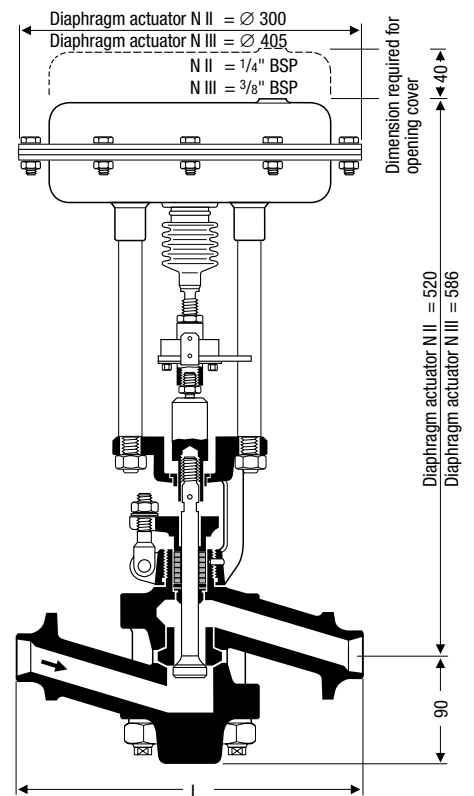

Rapid-Action Intermittent Blowdown Valves

(M)PA 46, PN 40, DN 20-50

(M)PA 47, PN 63, DN 25, 40, 50

(M)PA 110, PN 250, DN 25

Calculation of boiler water quantity to be discharged according to formula:

$$A = \frac{Q \cdot S}{K - S}$$

Conductivity of feedwater: S [μ S/cm]

Admissible conductivity of boiler water: K [μ S/cm]

Boiler capacity: Q [kg/h]

Boiler water quantity to be discharged: A [kg/h]

Example

Conductivity of feedwater: S = 20 μ S/cm

Admissible conductivity of boiler water: K = 4000 μ S/cm

Boiler capacity: Q = 2000 kg/h

Boiler water quantity to be discharged: A \approx 10 kg/h

Reading chart 1

Boiler pressure: 25 bar

Nominal size of intermittent boiler blowdown: DN 32

Flowrate: 2.5 kg/s

Chart 1

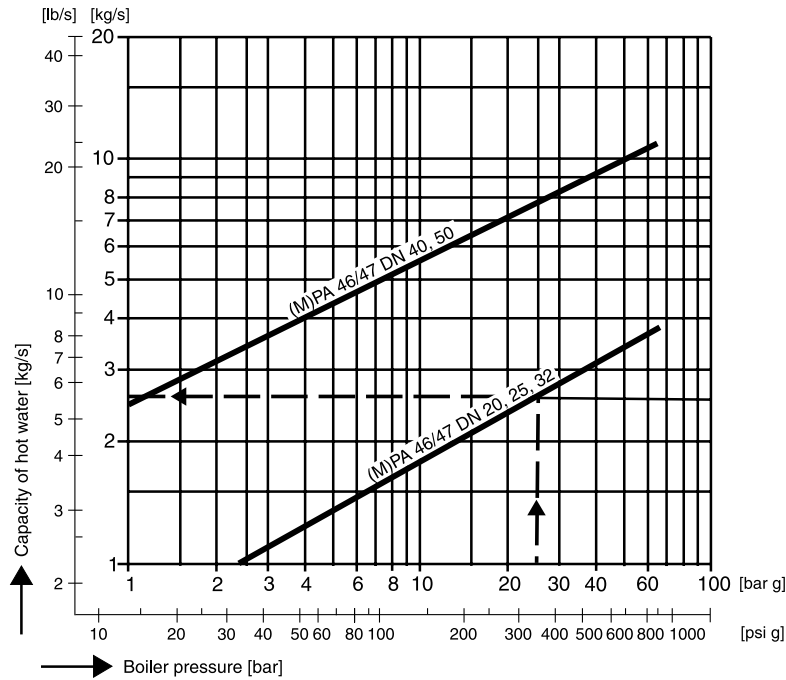
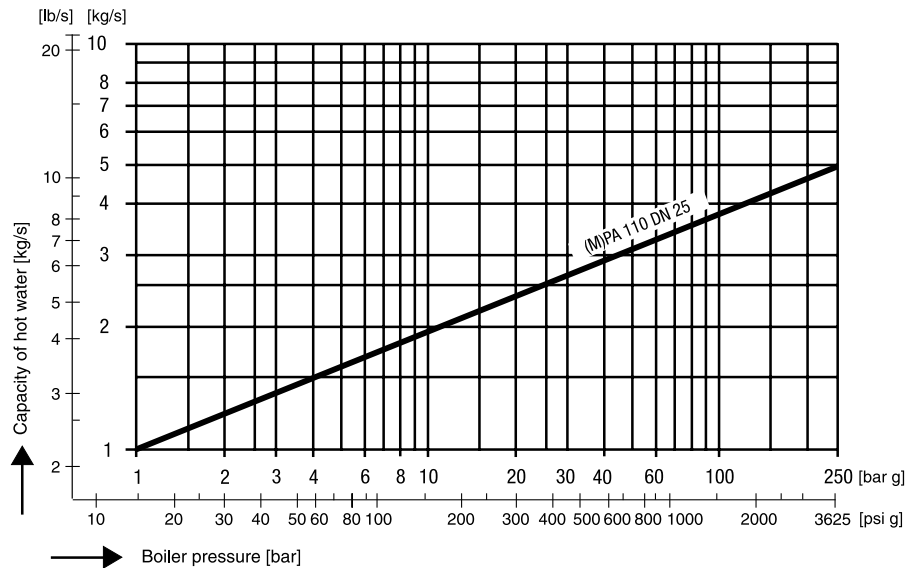

Chart 2



K_v-values	
(M)PA 46/47 DN 20, 25, 32	5.1 m ³ /h
(M)PA 46/47 DN 40, 50	16.5 m ³ /h
(M)PA 110 DN 25	6.1 m ³ /h

When ordering please state

Steam pressure, back pressure, amount of condensate, connection, size (DN), application (e. g. type of boiler or steam user).

The following test certificates can be issued on request, at extra cost:

In accordance with EN 10204/2.2 and -3.1 B.

All inspection requirements have to be stated with the order. After supply of the equipment certification cannot be established. For tests and inspection charges please consult us.

Supply in accordance with our general terms of business.

PED

The equipment meets the requirements of the Pressure Equipment Directive (PED) 97/23/EC. The equipment can be used for fluids of group 1 and 2.

With CE marking (apart from equipment in accordance with Article 3.3). For more information refer to our Declaration of Conformity with PED.

ATEX

The equipment meets the requirements of the ATEX Directive 94/9/EC and can be used in potentially explosive zones 1, 2, 21, 22 (1999/92/EC). For more information refer to our Declaration of Conformity with ATEX.

GESTRA AG

P. O. Box 10 54 60, D-28054 Bremen

Münchener Str. 77, D-28215 Bremen

Telephone +49 (0) 421 35 03 - 0, Fax +49 (0) 421 35 03 - 393

E-Mail gestra.ag@flowserve.com, Internet www.gestra.de

